

# Realization of Decision Making Based on Subject Collections

H.Vissia, G.Shakah, A.Valvachev

Belarus State University, 4 Nezavisimosty av., Minsk, 220050, Belarus, e-mail: h.vissia@byelex.com  
 Dept. of Information Technology, Ajloun National University, P.O.Box 43 Ajloun, 26810 Jordan, e-mail: warsaw2000@yahoo.com

Belarus State University, 4 Nezavisimosty av., Minsk, 220050, Belarus, e-mail: van\_955@mail.ru

**Abstract:** The paper describes the use of subject collections, multi-agent approach and cloud computing for constructing decision support systems. Unification algorithms for subject collection building and decision making are presented.

**Keywords:** Decision support systems, subject collections, cloud computing

## 1. INTRODUCTION

The article continues a series of papers devoted to the intellectualization of the decision making based on subject collections [1, 2, 3, 4].

Earlier, several models were constructed as the theoretical basis of the solution. The present paper considers unified algorithms for the application of the models with the aim to construct, use, evaluate and update subject collections. The realization of the algorithms in the form of software technology is also under consideration. An expert is considered as a source of knowledge for the construction of subject collections.

## 2. PROBLEM STATEMENT

In general, a Decision Making Problem is reduced to a choice of one or more alternatives from a variety of preset options.

The subject collection (SC) is an abstract structure that integrates homogeneous models of knowledge as components of the general solution [1]. Participants in SC life cycle are: the solution initiator (C), the knowledge source (E) and the user of the knowledge (U).

A model of the SC is developed [1]. The model ensures identification of the SC in the global environment taking into account the roles of all participants (actors) in decision making (Fig. 1).

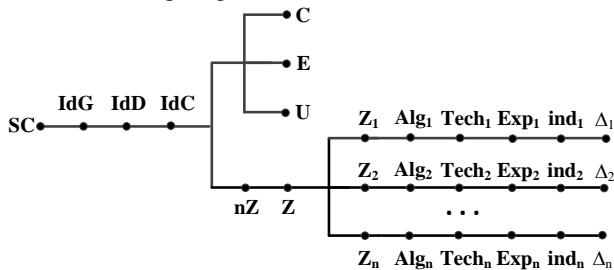

Fig.1 – The structure of a subject collection.

It is necessary to develop:

- an algorithm of SC initialization and construction;
- an algorithm of SC search and selection that meets user's requirements;
- an algorithm for evaluating usefulness of SC content;
- an algorithm of SC correction based on users' evaluation;
- a scheme of SC construction from various modules

written in different programming languages;

- an architecture of a decision support system based on subject collections;
- a portal for working with subject collections;
- portal use cases for solving applied problems.

## 3. ALGORITHM

Algorithms for data processing in Web applications are rather complex and require large memory, thus making them difficult for understanding. To solve the problem, a language consisting of the following operators is proposed:

- $\omega(i/d, nZ)$  – initialization (i) or deleting (d) SC nZ;
- $\psi(res/nZ, kr)$  – resource (res) or SC (nZ) search;
- kr – search criterion;
- $\phi(k, inf)$  – replacement of the n-th SC component with inf;
- $\Omega(C/E/U)$  – legitimization of actors;
- $\beta(nZ)$  – SC representation from a cloud resource on the user's computer;
- \* – blank parameter value;
- – continuation of the process;
- – end of the process;
- SP – software platform for SC life cycle realization;
- use – exit from SC (practical use of the content)

The language ensures concise and capacious description of algorithms. Each operator can be easily implemented in a method realized in any object-oriented programming language.

Let's describe algorithms for the solution of the above-stated problems using the language operators.

**The algorithm of SC initialization** by the center and **content construction** by the expert:

Step 1: SC initialization

C:  $\psi(res, *) \rightarrow$   
 $\Omega(C) \rightarrow$   
 $\omega(i, nZ, *) \rightarrow DB\_SC(nZ, Z \neq \emptyset, Alg, Tech, Exp, ind,$   
 $\Delta = \emptyset) \rightarrow$   
 $DB\_AC(E \neq \emptyset, Exp = \emptyset);$

Step 2: SC construction

E:  $\psi(res, *) \rightarrow$   
 $\Omega(E) \rightarrow$   
 $\psi(nZ, *) \rightarrow nZ, Z \rightarrow$   
 $SP \rightarrow$   
 $DB\_SC(\phi(3, Alg), \phi(4, Tec), \phi(5, exp));$

As a result, the center forms SC pattern, the expert constructs the content and places it into the pattern.

**The algorithm of SC search and selection** by the user:

U:  $\psi(res, *) \rightarrow$   
 $\Omega(U) \rightarrow$   
 $\psi(nZ, ind = max)$  or  $\psi(nZ, ind = 1..k) \rightarrow$   
 $\beta(nZ_j); \rightarrow use;$

As a result, the user performs search and selection of a subject collection.

**The algorithm of SC usefulness evaluation** by the user:

U:  $\psi(\text{res}, *) \rightarrow$   
 $\Omega(U) \rightarrow$   
 $\psi(nZ, j) \rightarrow$   
 $\text{DB\_SC}(\varphi(10, \text{ind}), \varphi(11, \Delta i));$

As a result, the user, on the basis of his own experience, introduces the value of content usefulness into a subject collection and makes suggestions for the content improvement. Currently, many users put their own assessments in the global data storage (Facebook, Twitter, etc.), thus increasing the reliability of estimates due to large-scale discussions in relevant subject areas.

**The algorithm of SC content correction** by the expert:

E:  $\psi(\text{res}, *) \rightarrow$   
 $\Omega(E) \rightarrow$   
 $\psi(nZ, j) \rightarrow$   
 $\text{DB\_SC}(\varphi(i, \Delta));$

As a result, the “aged” content elements, found by independent users, are replaced by the expert with the more advanced. Thus, there is an inverse relationship between SC content and environment requirements. Accordingly, the SC content can be considered up-to-date.

#### 4. SCHEME OF SC CONSTRUCTION

Capabilities of modern software and cloud technologies, needed to implement the architecture, have been analyzed. It is shown that an effective tool for SC construction is MS.NET software platform, which provides synthesis of the executive code based on different languages (Prolog, C++, etc.) [5]. The scheme of content construction with the use of NET in combination with other means is shown in Fig.2.

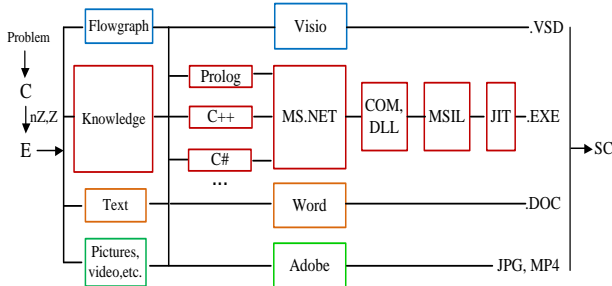

Fig. 2 – The scheme of SC construction.

MS.NET software platform is transparent, so the list of knowledge representation languages is constantly expanding. Thus, the problem of reentrance of diverse knowledge representation is being gradually solved.

#### 5. SYSTEM ARCHITECTURE

In accordance with the purpose of the paper, the architecture must ensure the functioning of the processes in a distributed environment with the use of cloud technologies [7] and devices of various types (PCs, smartphones, tablets).

It is shown that typical DSS architectures mainly use a local paradigm and do not provide a solution to the above-mentioned problems. A methodology for constructing a

new architecture is proposed. The methodology is based on the replacement of a typical local paradigm with an open one. As a result, there is a possibility of the distributed processing of the content and unlimited expansion of SC users.

A multi-agent approach is used for implementing the methodology. The approach is originally designed to solve distributed problems. The corresponding architecture (Fig.3) is proposed.

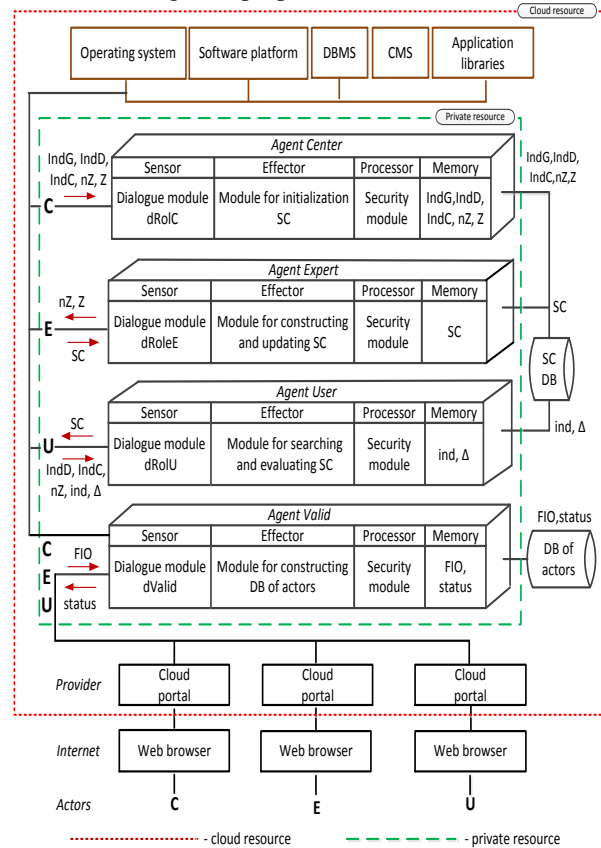

Fig. 3 – The general scheme of the architecture.

The architecture includes Cente(C), Expert(E), User (U) agents implementing basic processes Pr1 (SC initialization), Pr2 (content creation and updating), Pr3 (decision making and evaluation of content usefulness), as well as a validation agent (Valid) for regulating access to resources.

All agents are built on the single basic scheme <sensor-effector-processor-memory>. Specific features of their tasks in a distributed environment are taken into account.

The use of the universal XML database of SCs and implementation of dialogues through a Web browser facilitate the architecture integration into a variety of external environment, including a cloud one.

The autonomy of agents ensures the homeostasis of the architecture within changes of environment requirements. Integration into the cloud structure gives the possibility to unlimited increase the number and volume of SCs and improves the content security.

The use of interfaces of the cloud provider ensures access to SCs from different types of devices (PCs, smartphones, tablets), which contributes to the increase of the number of content users [7].

## 6. SYSTEM REALIZATION

Drupal's open source is used for building a web-system [6]. The source includes the Apache server and PHP language. The portal "Subject Collection" is designed and hosted in the cloud resource of Byelex company on the basis of the chosen software (Fig. 4).

The technique of using the portal for practical applications is developed. Access control, creation, updating and evaluation of subject collections have been tested.



Fig.4 – Internet portal: "Subject Collections".

Examples of the developed local and network SCs for decision making support in the field of medicine: "Orthopedische Casuïstiek" (for orthopedists); "Atlas van de Parodontale Diagnostiek" (for dentists); "Atlas Mond- & Kaakziekten" (for dentists); "Atlas of Forensic Medicine" (for forensic medical examination).

It is shown that the portal services ensure aggregation and representation of SC fragments in various ways, i.e. from the text to subject collections of illustrations (Fig. 5). This greatly simplifies the preparation of paper, CD and Web publications.



Fig. 5 – The result of the synthesis of various SC fragments

The use of MS.NET for constructing SC content ensures the solution to the problem of interoperability of knowledge represented in different languages.

The integration of the corporative portal resource into the cloud one makes it possible to reduce expenses for the purchase and support of the life cycle of OS, software and hardware due to the inheritance of constantly updated resources of the provider.

## 7. CONCLUSION

The following main results are obtained:

- the algorithm for constructing and updating subject collections of distributed experts, thus ensuring the permanent improvement of the content, is developed. As a result, the problem of knowledge "aging" is largely solved and the time from the appearance of an innovation to its implementation is reduced;
- the two-step decision-making algorithm is developed on the basis of the meta-model content. At the first step, a group of solutions proposed by different experts is chosen. The second step concerns the selection of the decision with maximum independent evaluations, thus ensuring to make a solution adequate to the environment state and permanently improve the content through the use of the external expertise;
- the distinctive technology for building computer systems to support decisions on the basis of subject collections with the use of the cloud approach is developed. As a result, the expenses for the development of the system and the support of the life cycle of software and hardware are considerably lowered.

## 8. REFERENCES

- [1] H.Vissia The Problem of Interoperability of Heterogeneous Models of Knowledge in Decision Making // *Vestnik BSU*. Issue 1. 2012. № 1. pp. 133-135.
- [2] V.Krasnoproshin, A.Valvachev, H.Vissia. Unstructured Knowledge Synthesis for Decision-Making Problems // *Proceedings of the Seventh International Conference PRIP'2003*, Minsk, v.1, 2003. pp.145-149.
- [3] V.Krasnoproshin, V.Obraztsov, H.Vissia Decision-Making by Precedence: Modeling, Technology and Applications // *Proceedings of International Conference on Modeling and Simulation in Technical and Social Sciences (MS'2002)*. Girona: Spain, 2002. - pp. 267–277.
- [4] G.Shakah Evaluation of Distance Learning Quality Base on Pattern Recognition // *Proceedings of the International Conference on Modeling and Simulation (MS'2004)*, Minsk, 2004. P. 320-323.
- [5] J.Richter Applied Microsoft .NET Framework Programming. – Microsoft Press, 2008. 632 p.
- [6] J.VanDyk, M.Westgate Pro Drupal Development. Apress, 2007. 428 p.
- [7] M.Miller Cloud Computing: Web-Based Applications That Change the Way You Work and Collaborate Online. QUE: 2008. 296 p.